

MANUAL
of Operating & Installation
Procedures
for

DIGITAL PANEL METER

Model AN2535

ANALOGIC 

WARRANTY

Analogic AN2535 Digital Panel Meter

Your AN2535 Digital Panel Meter has been carefully inspected and tested before shipment. Should a failure resulting from defects in material or workmanship occur within 90 days after shipment, such failure will be repaired and the unit recalibrated and tested at no charge. Non-catastrophic failures resulting from mis-use, improper connection, etc. will be repaired for a flat charge of \$25.00 during this period.

For a period extending from ninety days after shipment to one year after shipment, non-catastrophic failures of any nature (regardless of cause) will be repaired at a flat charge of \$25.00.

NOTE

AN2535 Digital Panel Meters are factory sealed units. The only user adjustment which may occasionally be necessary is accessible by simply moving the polarizing filter.

Because extensive damage may result from attempts by untrained personnel to measure circuit parameters or troubleshoot the unit, the warranty is automatically voided if the unit has been removed from its case.

OEM customers utilizing AN2535 units in quantity should contact the factory for information concerning special OEM warranty services.

CONTENTS

	<u>Page</u>
Standard Warranty	2
Introduction	4
Specifications	5
Installation	6
Adjustments and Options	9
Principles of Operation	12
Maintenance	15

FIGURES

Figure 1	AN2535 Simplified Block Diagram	6
Figure 2	AN2535 Possible Mounting Arrangements	6
Figure 3	AN2535 Outline Dimensions	8
Figure 4	AN2535 Connector Pin Designation	8
Figure 5	AN2535 Conversion Rate Control	9
Figure 6	AN2535 Common Mode Voltage Schematic	10
Figure 7	AN2535 Current Measurement	10
Figure 8	AN2535 Measurement of Voltages-Greater than 1.999 V	10
Figure 9	AN2535 3-Phase System Timing Diagram	16
Figure 10	AN2535 Detailed Block Diagram	16

INTRODUCTION

GENERAL DESCRIPTION

The Analogic AN2535 is the first of a new generation of digital panel meters designed particularly for many OEM applications. This "logic-powered" 3 1/2 digit DPM features the lowest cost available on the market at performance levels consistent with previous Analogic DPM designs.

This first of a family of DPMs has been designed for OEM applications in which a +5 Volt logic supply is available. Elimination of the integral power supply for AC line operation results in significant cost and size optimization.

PERFORMANCE ACHIEVEMENTS

The power requirements from the +5 Volt supply have been carefully minimized in the design to do away with self-heating effects. The AN2535 uses only 3.5 watts of power -- less than half that used in traditional designs -- inherently increasing stability, reliability, and life.

Differential input, 1000 Megohm input impedance, common mode rejection ratio of over 100dB, and choice of full scale input ranges provide users of the AN2535 Digital Panel Meter with practically unlimited system applications. In addition, an integral DC to DC converter in the AN2535 completely separates analog and digital supplies. This true separation eliminates effects of TTL logic current spiking and display current variation from critical analog paths.

MECHANICAL ACHIEVEMENTS

The AN2535 has the smallest front panel size available on the market, less than 1.4 inches high, yet features a larger character size than any comparable meter. This allows the AN2535 to be used in a standard 1 3/4 inch panel, and in addition, permits a wide angle of view at extended distances. The total volume is also but 6.8 in³ -- the smallest available by far.

ANALOG INPUT

Configuration	Bipolar, floating differential
Full Scale Range	$\pm 1.999V$ AN2535-1 $\pm 199.9mV$ AN2535-01
Bias Current	1nA
Input Impedance	1000M Ω

ACCURACY/STABILITY

Absolute Accuracy	0.05% reading ± 1 count
Monotonicity	Guaranteed
Temperature Coefficient	50PPM/ $^{\circ}C$

CONVERSION

Technique	3-Phase, dual slope, auto-zero, complete conversion in each cycle
Rate	Internal Trigger - 2/sec Nominal. Factory or user adjustable External Trigger - Sample and Hold or up to 100 conversions/sec

COMMON MODE

Rejection Ratio (CMRR)	$> 70dB$ @60Hz without filter; $> 100dB$ with filter
Voltage (CMV)	$\pm 0.25V$ AN2535-1 $\pm 2V$ AN2535-01

DISPLAY

Type	7-segment, in-plane, incandescent (0.5" nominal height)
Number of Digits	3 full decade digits, plus overrange "1" digit
Decimal Point	Externally programmable 3 positions
Polarity	Automatic + or - sign
Overload (> 1999 counts)	MSB = 1, 3 least significant digits blanked

DIGITAL SIGNALS

Logic	DTL/TTL compatible
	Input: 2 loads
	Output: 1 load
External Trigger	Converts on falling edge; see Timing Diagram
Rate/Hold	Conversion "held" by grounding terminal through 5.1K Ω . Rate externally adjustable (See Fig. 5, Page 9).
BCD Output Data	3 BCD digits, polarity, and overrange "1"
Polarity	Positive: low level; Negative: high level
Overload (> 1999 counts)	Output high
End of Conversion	Transition from high to low for EOC

POWER

Input	+5V \pm 0.25V @700mA (3.5 watts)
-------	------------------------------------

ENVIRONMENTAL, PHYSICAL, &RELIABILITY

Operating Temperature	-10 $^{\circ}$ C to +60 $^{\circ}$ C
Storage Temperature	-25 $^{\circ}$ C to +85 $^{\circ}$ C
Relative Humidity	0 to 95% non-condensing
Configuration	See Outline Drawing (see Fig. 3. Page 8)
Mounting Arrangement	Universal (see Fig. 2 Page 6)
Weight	< 5 oz.
Connector	30 pin, 0.156" spacing. Viking 2V-K15D/1-2; Amphenol 225-21521; or equivalent.
Warmup Time	Essentially none.
Overvoltage	Up to \pm 15V without damage
Recommended Recalibration	3 months interval
Calculated MTBF	> 80,000 hours

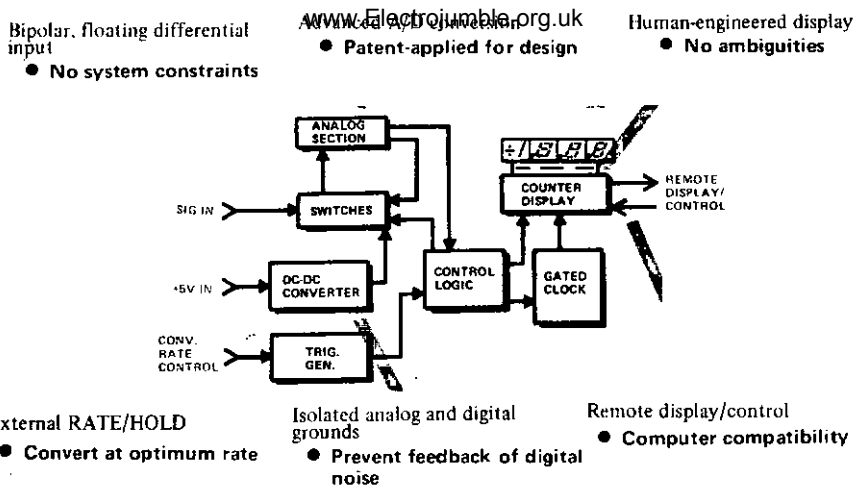

Figure 1. AN2535 Simplified Block Diagram.

INSTALLATION

MOUNTING

AN2535 features a universal mounting capability as standard -- front panel fastening, top or bottom PC board mounting, or support bracket assemblies are just a few of the many user conveniences built into the unit.

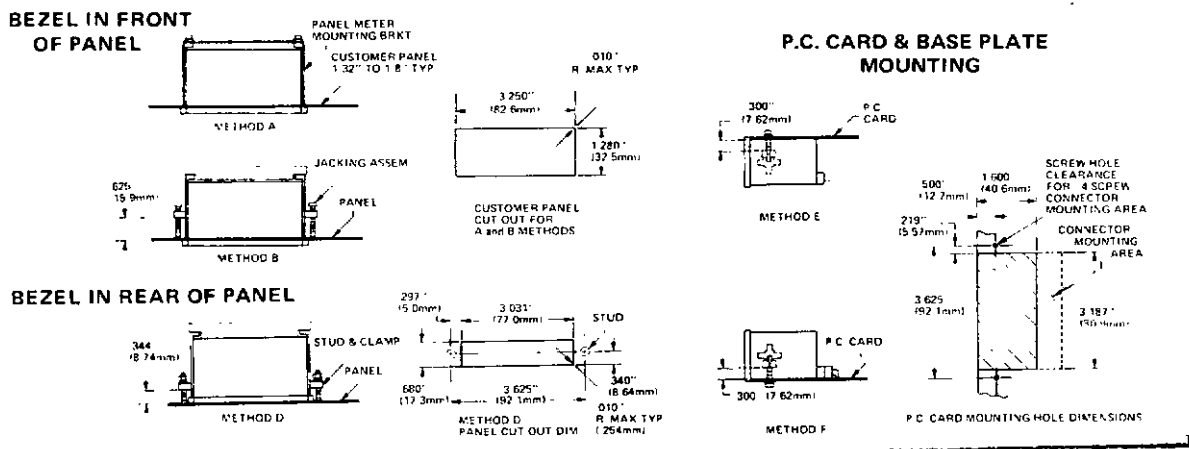

Figure 2. Five Possible Mounting Arrangements for AN2535.

POWER CONNECTIONS

WARNING

Follow instructions for power and remote digital connections very carefully. Double check all such connections before applying power.

All connections to the AN2535 DPM are made via the connector on the back of the case. The required mating connector is a standard Viking 2V-K15D/1-2, and cabling hook-up is shown in Figure 4.

REMOTE DISPLAY AND CONTROL

The connector, J1, is used for transmitting BCD conversions of the displayed 3 1/2 digits in DTL/T²L compatible signals capable of driving 1 load. The three least significant digits, identified DIG 1 through DIG 3 (DIG 1 is the least significant) are 1-2-4-8 coded; e.g. DIG 3 B4 is the bit whose high level indicates a decimal increment of 4 to the third (from right to left) decimal digit. The fourth (most significant) decimal digit has only one decimal increment. For the overload indication, the three least significant digits are blanked, the most significant digit is a "1", and the signal level output on pin J1-N rises past 2.2 volts. For negative inputs the negative sign appears automatically and the voltage output on pin J1-13 is high; and for positive inputs the positive sign appears automatically and the voltage output on pin J1-13 is low.

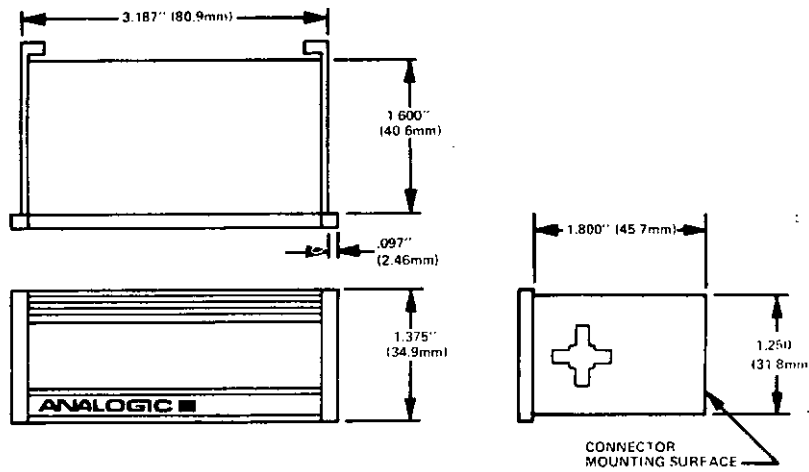

Figure 3. AN2535 Outline Dimensions

(OPT)*	A	1	SIG IN
ANA GND	B	2	SIG RTN
(OPT)*	C	3	(OPT)*
DEC PT 2	D	4	DEC PT 1
D1B2	E	5	D1B1
D1B4	F	6	D1B3
D2B2	H	7	D2B1
D2B4	J	8	D2B3
D3B2	K	9	D3B1
D3B4	L	10	D3B3
(OPT)*	M	11	DEC PT 3
OVERLOAD	N	12	D4B1
CONVERSION	P	13	POLARITY
EXT TRIG	R	14	HOLD/SAMPLE
(+5V RTN) GND	S	15	+5V

(OPT)* Pins available for options
AN2535 Connector Pin designations

Figure 4. AN2535 Connector Pin Designations

RANGE ADJUST

Model AN2535 Digital Panel Meter has one externally accessible built-in adjustment: for range scale. The range scale adjustment is accessible by moving the polarizing filter and locating the potentiometer shaft which is mounted on the extreme lower right corner.

The polarizing filter is moved by pivoting it about its top edge extensions. To accomplish this slide the filter up releasing the bottom edge from its retaining groove. Place a paper clip or other appropriate pulling instrument in the exposed notch in the center of the bottom edge. Pull the bottom edge up and out thus allowing the filter to pivot about its top edge.

To adjust the range scale apply an input voltage equal to within 1/2 the least significant digit. Then, adjust the full scale range potentiometer for a reading of the known value on the meter display.

Figure 5. AN2535 Conversion Rate Control

Model AN2535 Digital Panel Meter is factory-set to perform approximately 2 data conversions/sec. The conversion rate may be adjusted for greater or lesser values by adding external resistance or capacitance, respectively, as shown. Additionally, the meter may be controlled to perform data conversions only when externally commanded or to hold the results of a prior conversion until commanded by applying a control signal of the waveform as shown in the Timing Diagram to the EXTERNAL TRIGGER input. Connections of external components are shown in the accompanying illustrations.

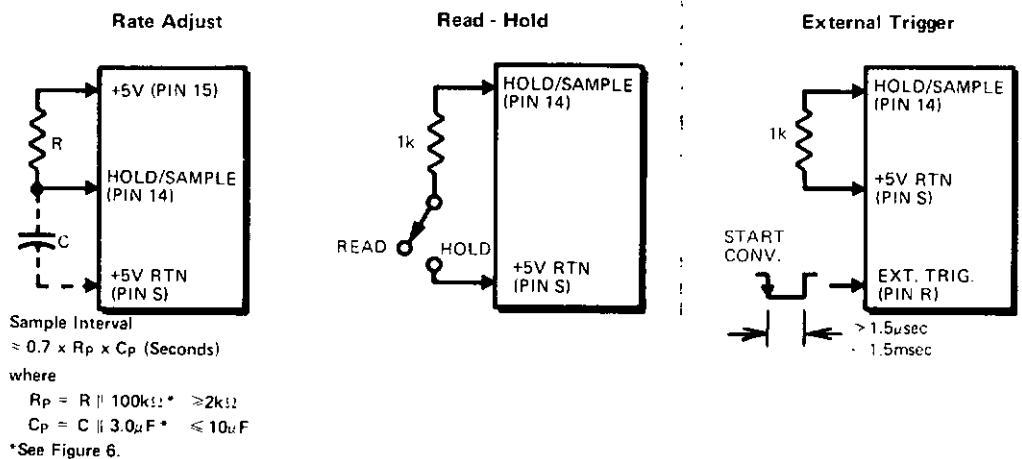

GROUNDING

As long as common mode voltage constraints are met (see Specifications), analog and digital grounds need not be connected together.

Figure 6. Common Mode Voltage Schematic

For single ended application connect SIG RTN (Pin 2) to ANA GND (Pin B)
 For differential application constrain E_{cm1} and E_{cm2} as shown

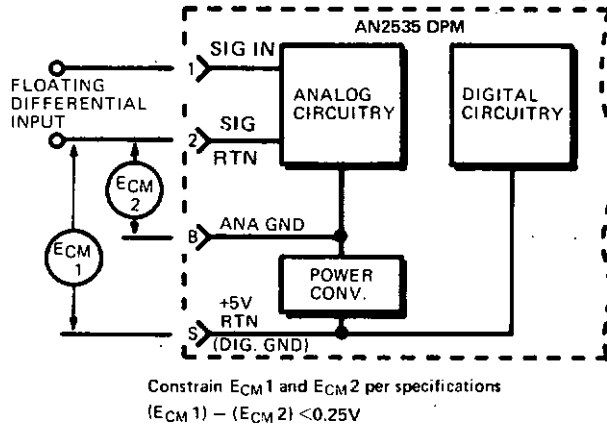
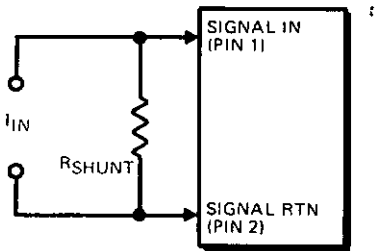

Figure 7. Current Measurement

To measure currents, connect a shunt of the calculated value across the input terminals.



$$R_{SHUNT} = \frac{\text{Desired F.S. count} \times Y}{\text{Current in Amp.}}$$

where

- $Y = 10^{-3}$ for 1.999V FSR
- $Y = 10^{-4}$ for 199.9mV FSR.

Figure 8. Measurement of Voltages >1.999V

$$R_B = \frac{(\text{Desired F.S.} - 1) \times R_A}{2}$$

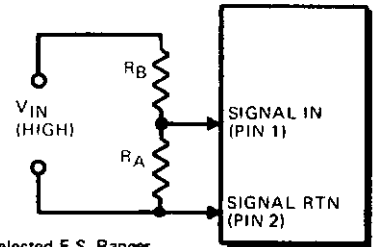

Values of R_A & R_B for Selected F.S. Ranges

		AN2535-01		AN2535-1	
Desired F.S.R	Desired F.S.R.	Nom. Input Z	R_A (Ω)	R_B (Ω)	
1.999V	19.99V	1M Ω	100K	900K	
19.99V	199.9V	10M Ω	100K	9.90M	
99.9V	999V	10M Ω	10K	9.99M	

RATIOMETRIC OPERATION

When the Ratiometric Operation Option is ordered, the output of the AN2535 can be calibrated to give the ratio directly or to give a number which can be read directly in units desired. The appropriate connections are as follows: Connect the reference voltage input to pin J1-A, and its return to pin J1-2. Connect the nominal signal input to pin J1-1 and signal return to pin J1-2.

LINEARIZATION

One of the options available for AN2535 Panel Meter operation is the application of a weighting function to the input signal. When the option is ordered, the oscillator output is connected to the counter via an external control circuit. The external components are used to suppress counts in accordance with the desired weighting function to be applied to the input signal. The resulting counts are then returned through the AN2535 connector to drive the 3 decade counter. In the typical application, the weighting function is used to linearize an input signal to compensate for non-linear properties of the sensor from which the analog input is derived. ANALOGIC field engineering services are available to assist users in the design of appropriate weighting function circuitry to be integrated with the panel meter operation

PRINCIPLES OF OPERATION

GENERAL

A block diagram is inserted at the end of this section for convenient reference in following the description of circuit operation. The information contained in this section is intended to permit users of the AN2535 digital panel meter to obtain maximum utility and versatility in their applications. The information is also presented in order to provide repair personnel with additional material to aid their servicing, fault isolation, and repair activities.

The functional block diagram (Figure 10) indicates the major subdivisions of the meter. The Analog section, consisting of the input filter, clamp and switching circuits, integrator, comparator, reference supply, and floating power supply is wholly contained in a guarded section coupled to the digital control circuits, counters, registers, and display.

The Analog section receives the input signal voltage and performs the 3-phase conversion under the control of the digital circuitry to deliver the control signals enabling the counter to accumulate the number of counts accurately proportional to the input voltage magnitude. The Analog portion also includes the necessary circuits to determine and store the compensating offset and to indicate the polarity of the input signal.

The sequence of operation, with reference to the block diagram of Figure 10 and the Waveform and Timing Diagram of Figure 9 occurs as follows---

Prior to receiving the trigger input, the Analog circuit is in the phase zero state in which switch conditions connect the offset memory into the feedback path of the integrator, remove the meter input from the input amplifier, and ground the input to that amplifier. The integrator and comparator develop a voltage across the offset memory capacitor in accurate proportion to the sum of any offset currents generated with zero input to the circuit.

Upon receipt of the trigger signal (whether internally or externally generated) the master control logic develops the necessary switch control signals through the coupling to the control logic in the Analog section. The trigger signal initiates phase 1 operation in which the voltage stored in the offset memory capacitor is algebraically combined in the integration functions. The meter input signal is connected to the input amplifier, and the clamp to ground of the amplifier is removed. The integrator begins to accumulate a voltage on the integrator feedback capacitor at a rate proportional to the magnitude of the input signal. Simultaneously, the master control logic gates the clock pulses from the oscillator into the 3 decade counter.

When the count reaches 1,000, signified by a third decade carry output, the master control logic develops the necessary control signal to initiate phase 2 operation.

At the start of phase 2 the register is 000, and either the plus or minus polarity switch is closed, depending upon the input signal polarity. The polarity indication is determined by the state of the comparator in the Analog section at the end of phase 1. The sensed polarity determines which of the polarity switches is operated, and through the master control logic develops the polarity sign indicator for the display.

During phase 2, the connected reference is integrated at a constant rate to decrease the voltage on the integrator capacitor while the counter accumulates the output of the clock. The end of phase 2 is signaled by the zero crossing at the output of the comparator which initiates the control pulses through the control logic to the master control logic of the digital section.

The end of phase 2 control signal holds the counter at the stored count which transfers the accumulated count of phase 2 to the display in digital form, while producing BCD equivalents for remote data transmission.

FULL SCALE, FULL SCALE RANGE, AND OVERVOLTAGE

The input voltage is considered to be a full scale value if the phase 2 integration period reaches exactly 1000 counts at the zero crossover event. If the input is such that the zero crossover occurs at 2,000 counts, then the information is identified as being full scale range, or 100% overrange related to the full scale count of 1,000.

If the phase 2 integration does not reach the zero crossover event prior to the accumulation of 2,000 counts, then the input is identified as an overvoltage. The counter and associated digital circuitry develop an end of phase 2 signal at the 2,000 count value and is used to generate the data transfer and End of Conversion information. However a different display and remote data transmission format is developed for overvoltage conditions. The most significant digit of the display (and the BCD equivalent) is a decimal 1. The remaining decimal digits of the display are blanked but BCD equivalent outputs are 999.

DECIMAL POINT

The decimal point may be programmed externally by grounding the appropriate terminal identified in the table of Figure 4. In selecting the decimal point location, it should be remembered that the decimal point named DEC PT 1 (for example) is lighted in DIG 1 and appears at the left (to the more significant side) of the indicated digit. In Full Scale Range of 1.999 V one would ground the terminal "DEC PT 3," connected to J1-11.

MAINTENANCE

Users of the AN2535 Digital Panel Meter should consult the factory for repair services even after the 90 day warranty period. Any repairs to the AN2535 should be made only by a highly skilled technician experienced in repairing densely packed miniaturized modern electronic instruments.

Access to internal circuitry is achieved by removing the right (viewing from the front) side plate which is held by two screws. After the plate is removed the PC board can be pulled out.

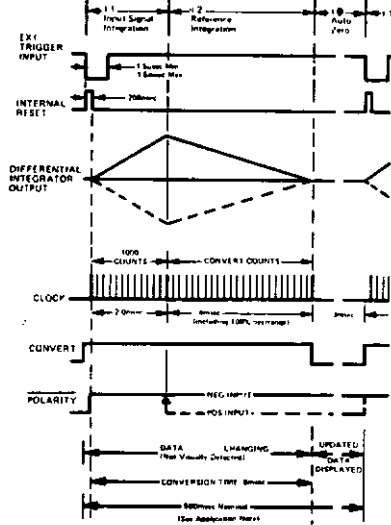

Figure 9. AN2535 3 Phase System* Timing Diagram

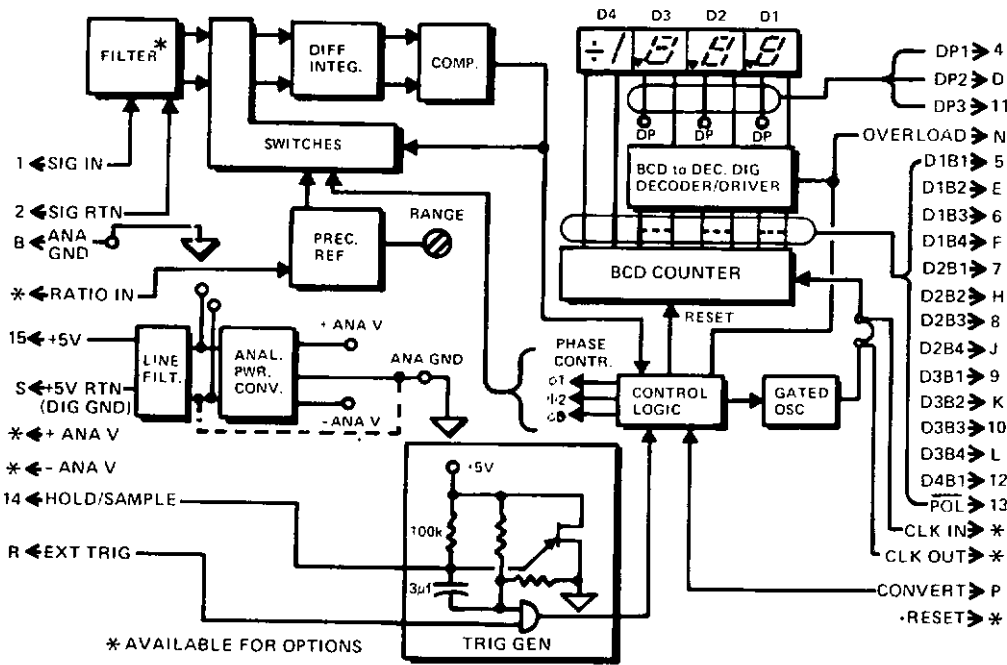

Figure 10. AN2535 Detailed Block Diagram